

Electric lift table 3.000Kg. Platform 1700 x 1200



Description

Electric scissor lift table 3.000 kg. Adjustable height to achieve a comfortable working position in all situations, assembly stations, control stations, as palletizing, machine output, etc.. Controlled by a pendant with emergency stop and safety frame to stop the descent if an obstruction. Gentle movements. Rectangular steel structure to ensure the stability and strength of the table. Safety bar. Motor with IP54 protection. Adjustable valve. Detachable shafts. Stabilizing rollers. Supply voltage 380V. CE Marked. Made to order, please contact us.

Technical data

Reference	10188-T
Dimensions mm base (length x width)	1.700 x1.200
Total lift	2.050 mm
Folded height	400 mm
Lifting time	55 sg
Motor Kw	2.2
Load	3.000 Kg
Weight Kg	520

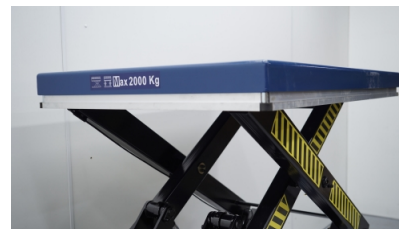
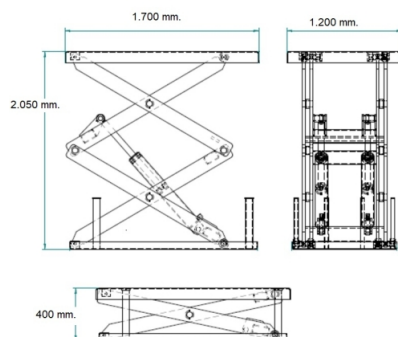

Electric lift table 3.000Kg. Platform 1700 x 1200

