

Implement vertical drum (sheet drum)



Description

Drum Transporter to easily and quickly lift without hydraulic or electric connections. Sturdy steel construction. Ideal for transport and lifts drums. Simple mechanism secure. Suitable for 220 liter drums. CE Marked.

Technical data

Reference	3043
Dimensions (mm) L x W x H	600 x 600 x 60
Turning Radius	
Weight Kg	70
Load	500
Drum	220

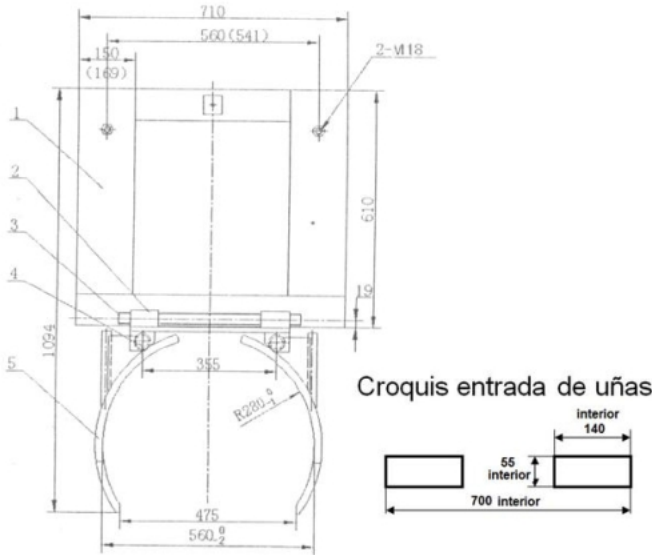

Implement vertical drum (sheet drum)

