

120 Lts Galvanized Bucket



Description

Galvanized container resistant to high and low temperatures. Stamped solid rubber wheels. Capacity of 240 liters. Rear handles to allow and facilitate its movement. Lid with hinges on the side edge of the handles and equipped with two grips for lifting. Easily washable with water.

Volume: 240 Liters

Material: Hot-dip galvanized, DC01

EN 840-1 certified

EN 4102-1 Fire resistance - Certified

Technical data

Reference	9821-GA
Dimensions (mm)	554 x 870 x 480
Fixed wheels Ø mm.	Ø 200
Weight kg.	25
Bandage	

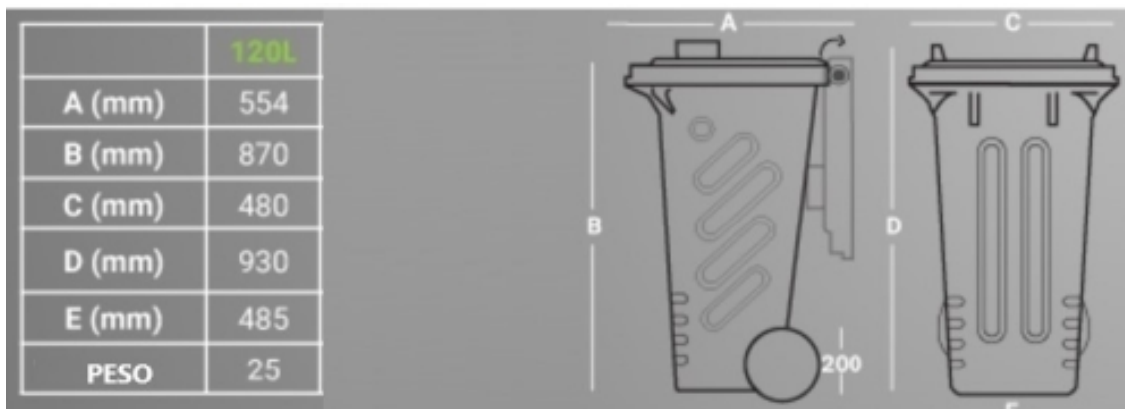

120 Lts Galvanized Bucket

