

TOLERANCIAS NO ESPECIFICADAS		
ARISTAS	LONGITUDES EN m/m	
CHAFALNES = 0.5x45°	DE 0 A 6 = ± 0.1	DE 120 A 400 = ± 2
RADIOS = 0.5	DE 6 A 30 = ± 1	DE 400 A 1000 = ± 2.5
ANGULOS = ± 1°	DE 30 A 120 = ± 1.5	MAS DE 120 = + 3

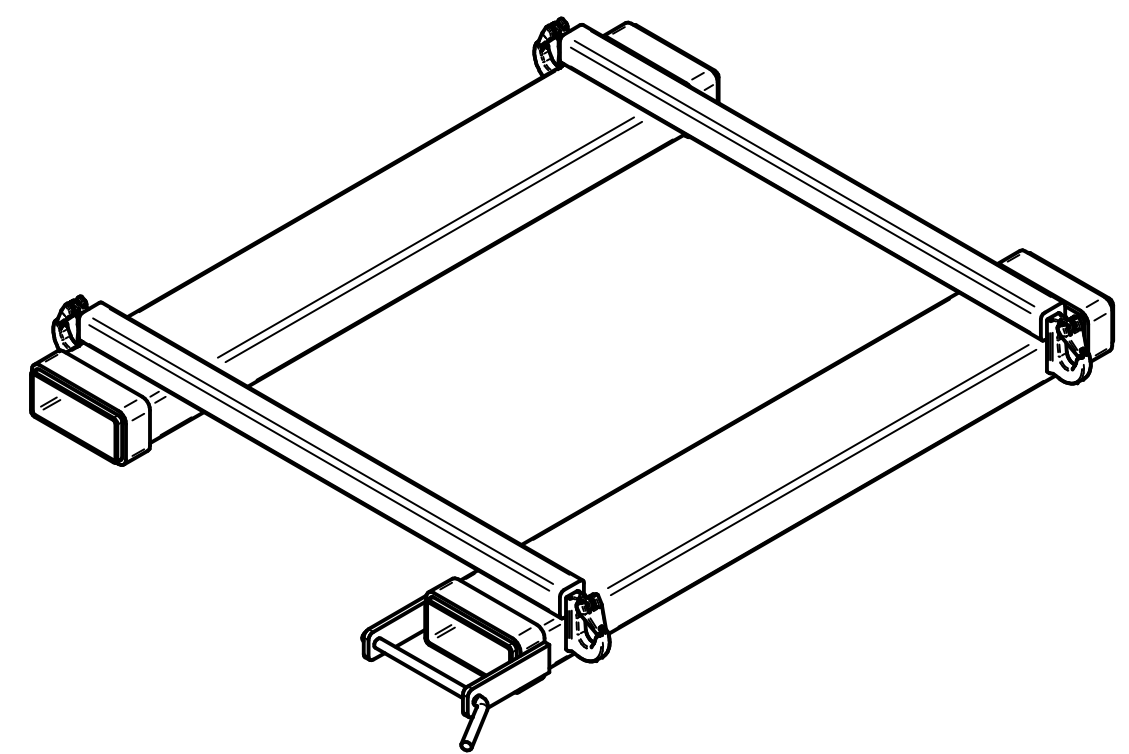
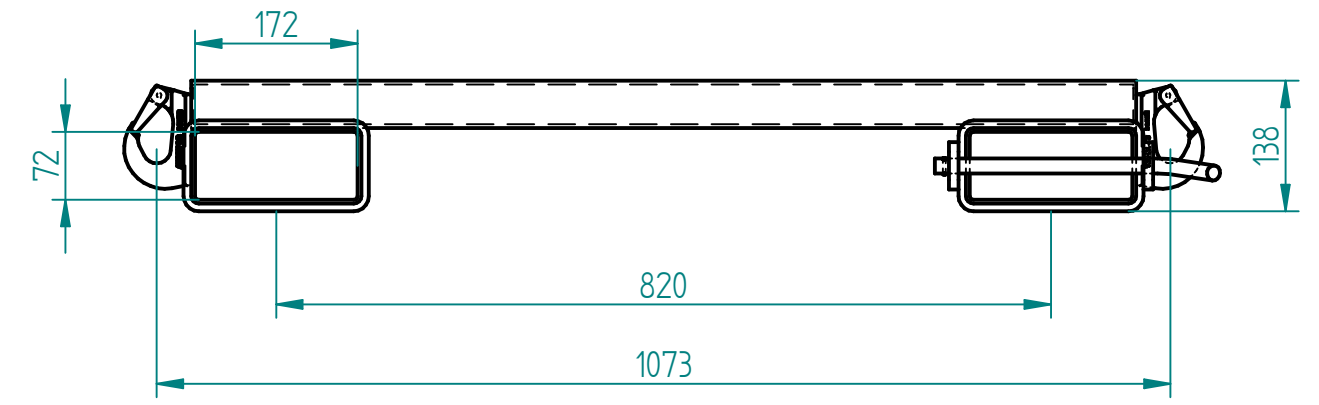

1.0	13/07/2021	IMPLEMENTO CARRETILLA BIG-BAG 2.000Kg	Usuario	R.Of.Técnica	R. Producción	R. Calidad
Rev.	Fecha	Descripción	Elaborado	Revisado	Verificado	Validado
3049-B		Referencia Plano:			Cliente:	Escala: 1:8
					Código: FQ. 73.01	1 de 1